

4

3

2

1

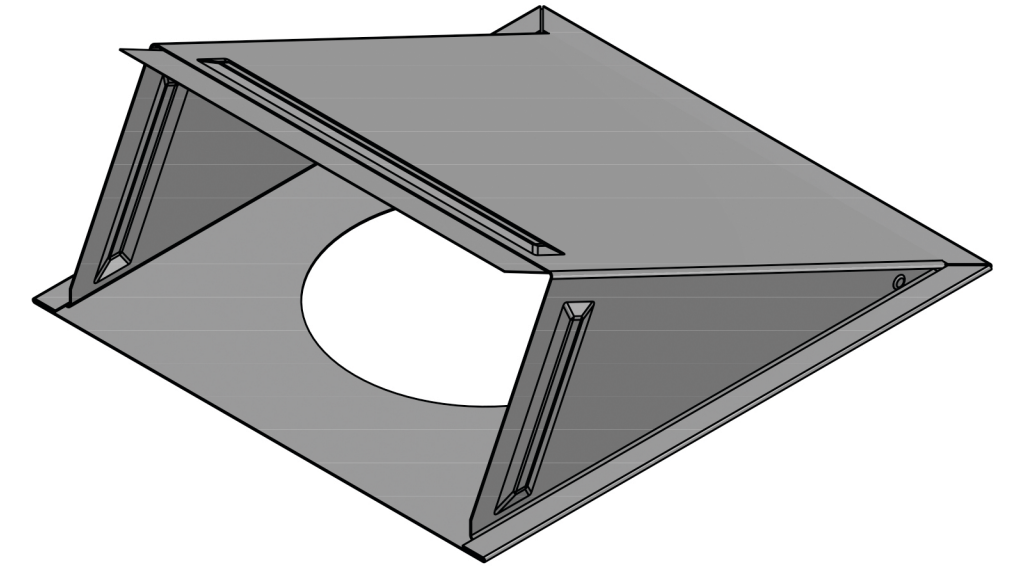
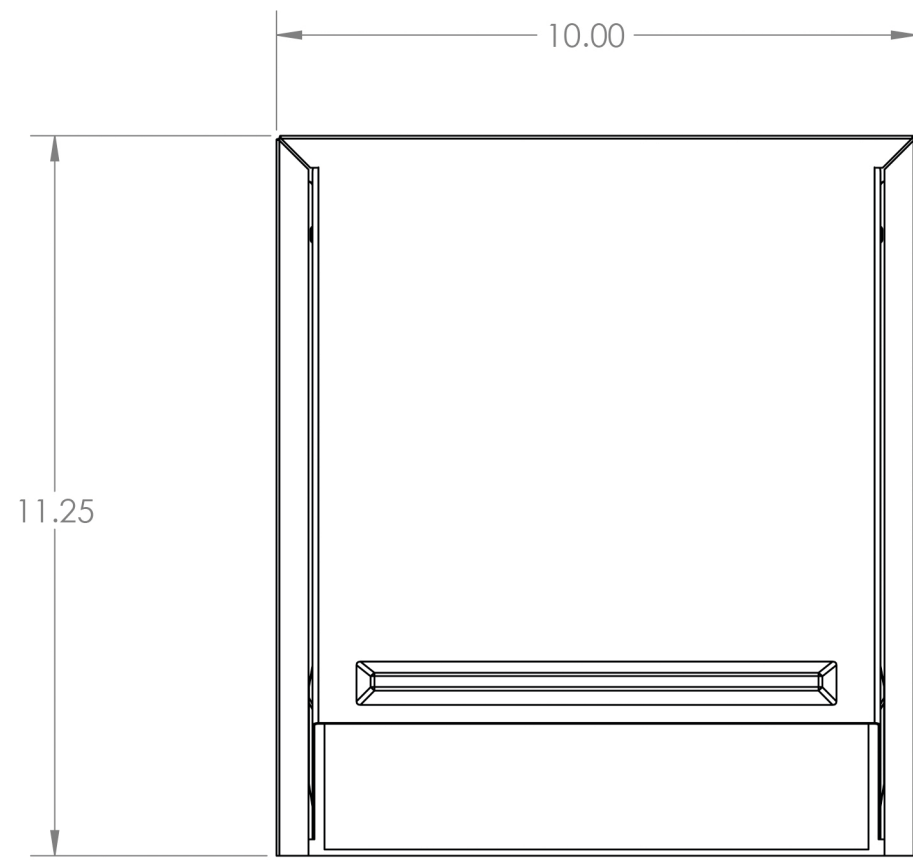

OPEN VENT

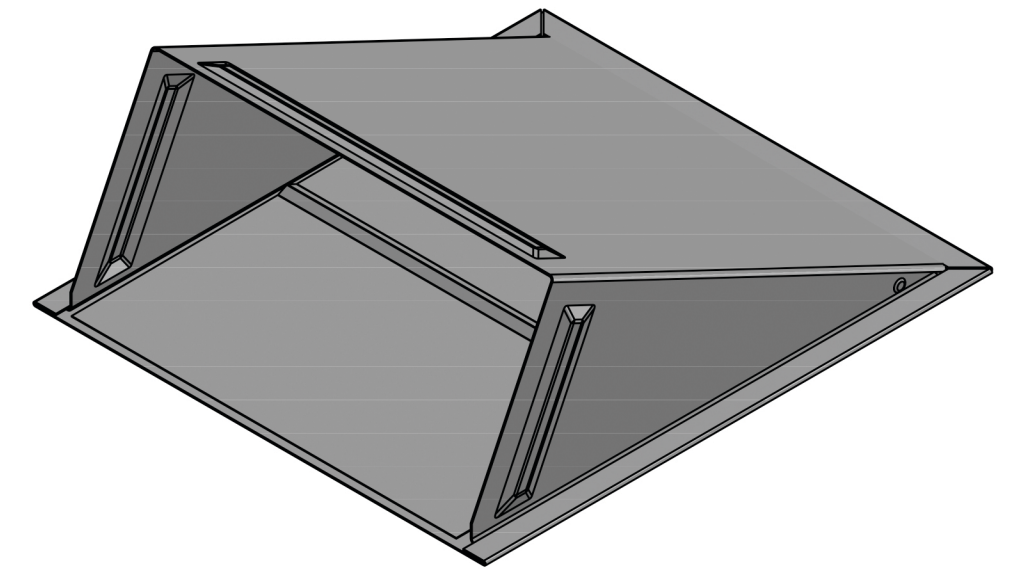
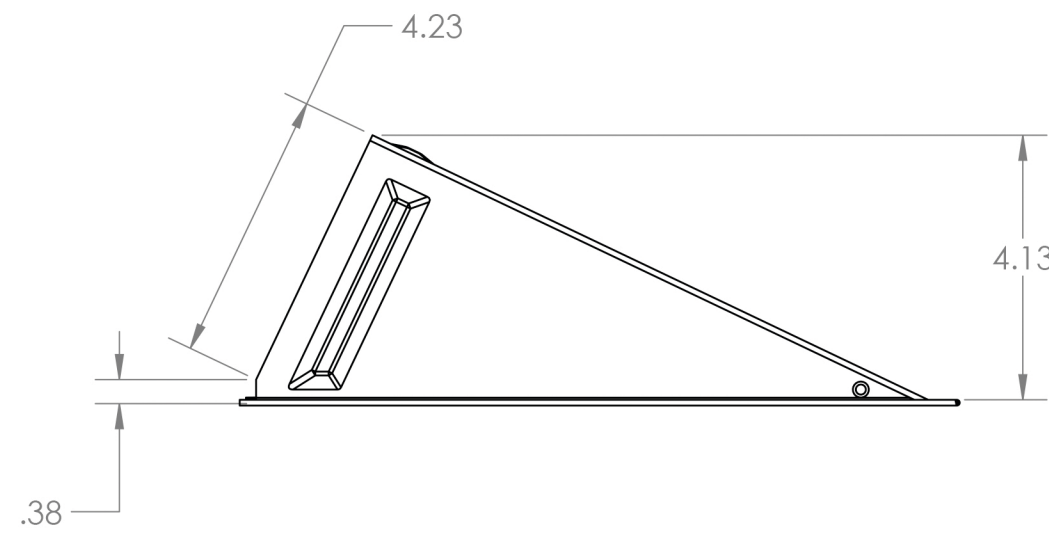
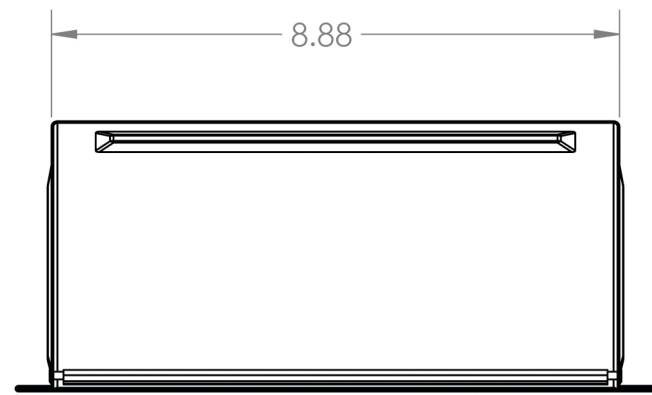

CLOSED VENT

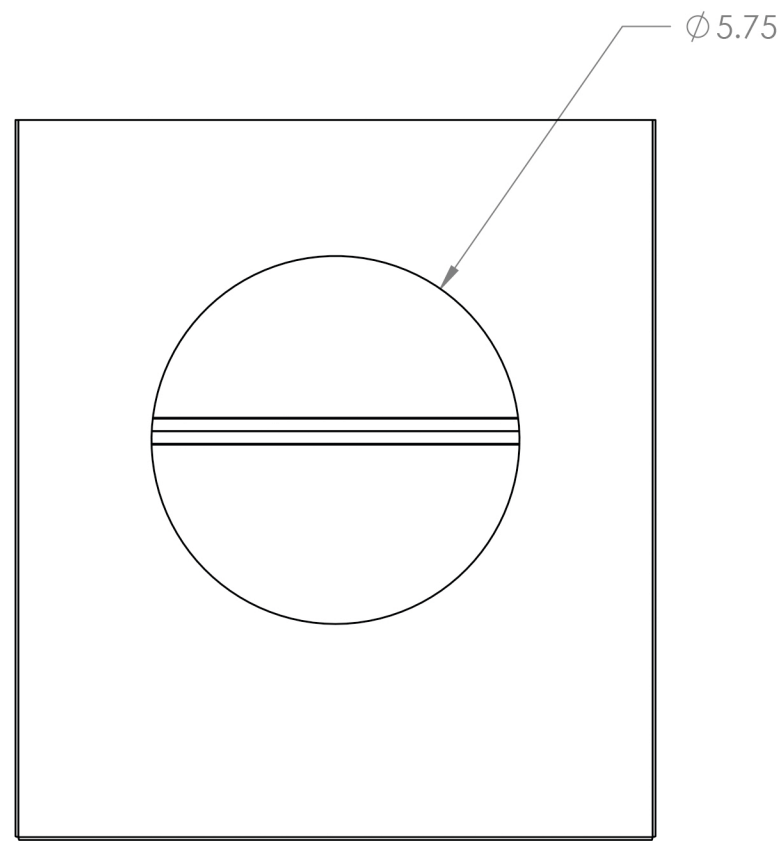

OPEN VENT WITH SCREEN AREA - 40 IN²

LAMBRO Lambro Industries, Inc.
 115 Albany Ave.
 Amityville, NY 11701
 (631) 842-8088
 www.lambro.net

PROPRIETARY AND CONFIDENTIAL
 THE INFORMATION CONTAINED IN THIS DRAWING IS THE SOLE PROPERTY OF LAMBRO. ANY REPRODUCTION IN PART OR AS A WHOLE WITHOUT THE WRITTEN PERMISSION OF LAMBRO IS PROHIBITED.

UNLESS OTHERWISE SPECIFIED:		NAME	DATE
DIMENSIONS ARE IN INCHES		DRAWN	
TOLERANCES:		CHECKED	
FRACTIONAL ± 1/16		ENG APPR.	
ANGULAR: MACH ± 1 BEND ± .01		MFG APPR.	
TWO PLACE DECIMAL ± 0.01		Q.A.	
THREE PLACE DECIMAL ± 0.005		COMMENTS:	
INTERPRET GEOMETRIC TOLERANCING PER:		Net Free Area (NFA)	
MATERIAL		34 sq. in.	
FINISH			
NEXT ASSY	USED ON		
APPLICATION			
		DO NOT SCALE DRAWING	

TITLE: 6" Galvanized Wall Exhaust Hood Vent
 Flush Mount - Damper
 Cover & Base: 26 Gauge
 Damper: 28 Gauge

SIZE	DWG. NO.	REV
	C 3460GNT	
SCALE: 1:3	WEIGHT:	SHEET 1 OF 1

4

3

2

1