

4

3

2

1

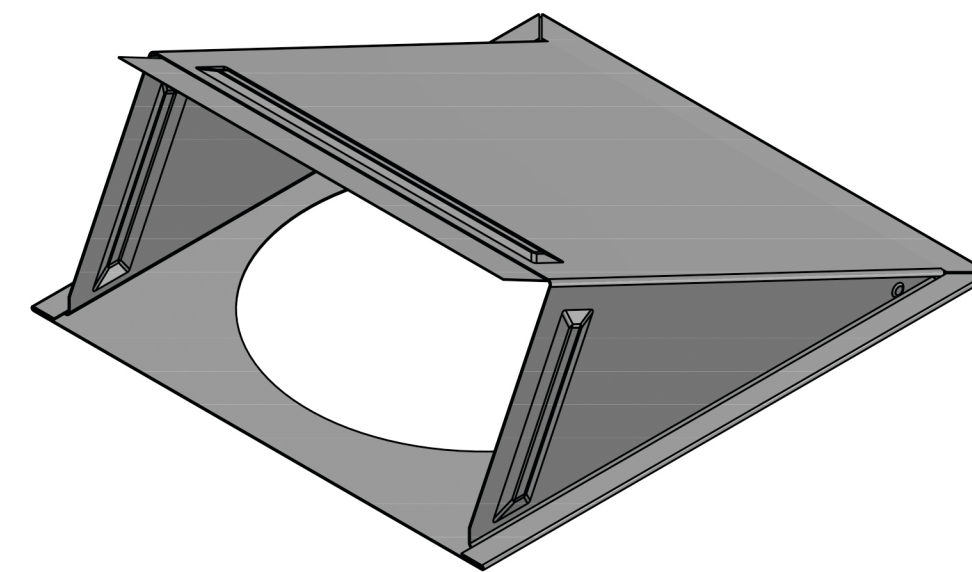
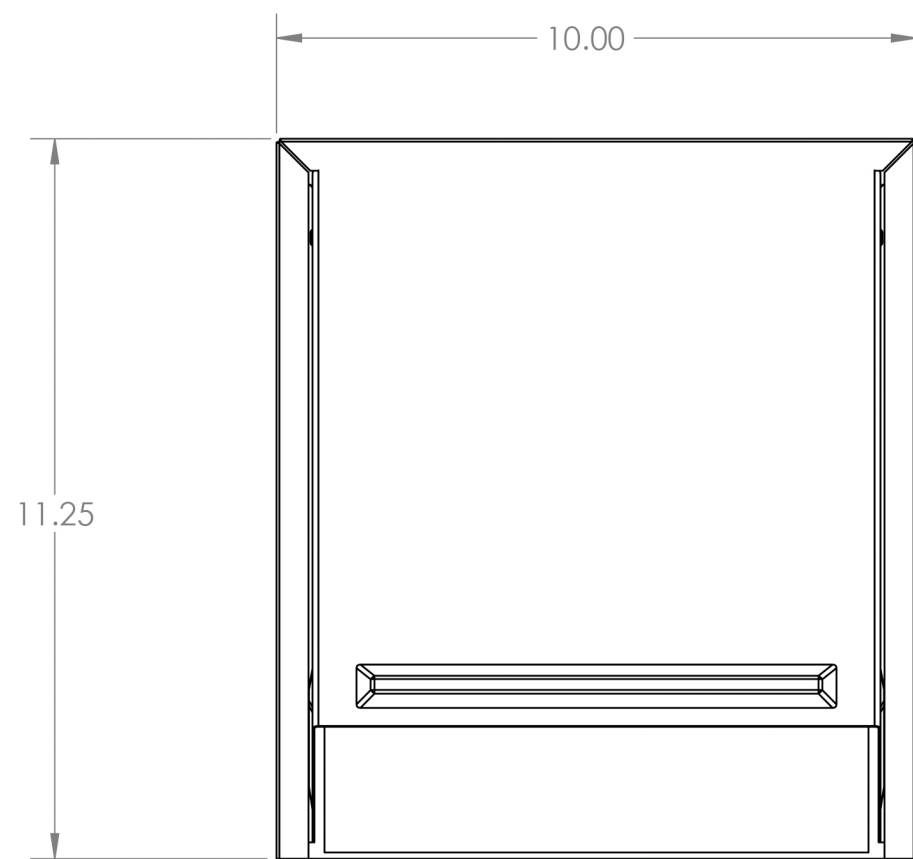

OPEN VENT

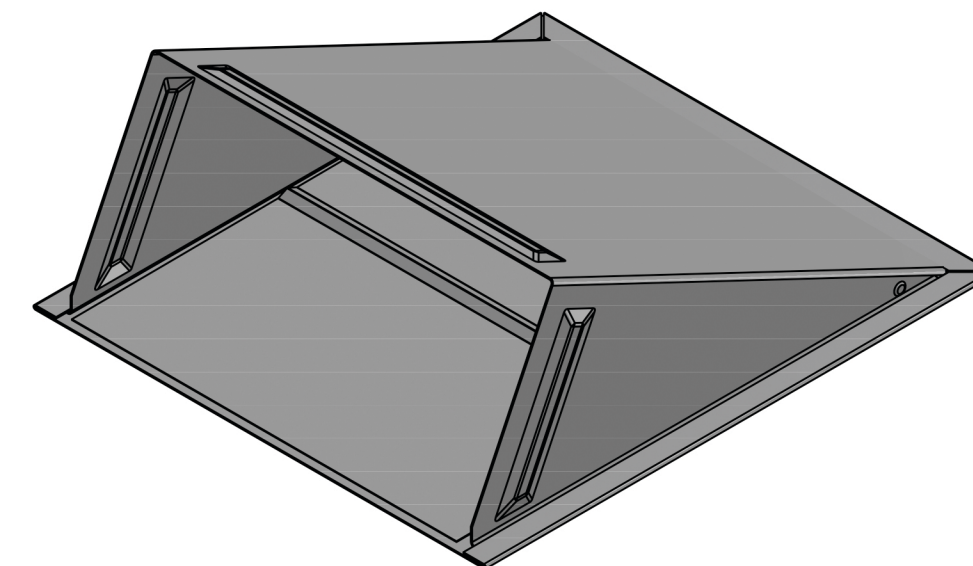
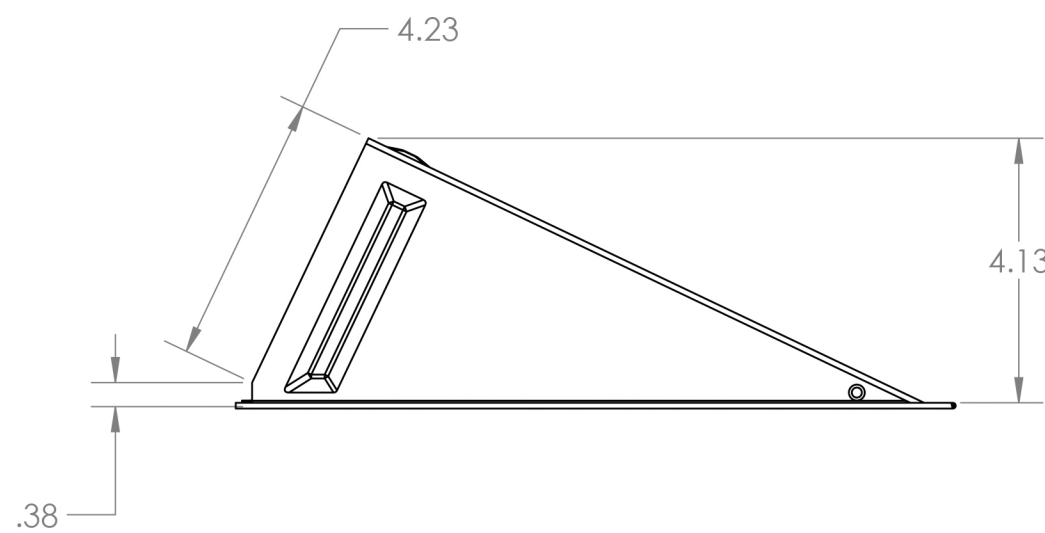
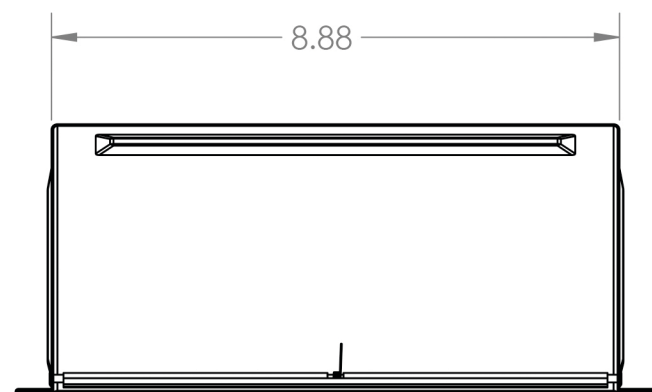

CLOSED VENT

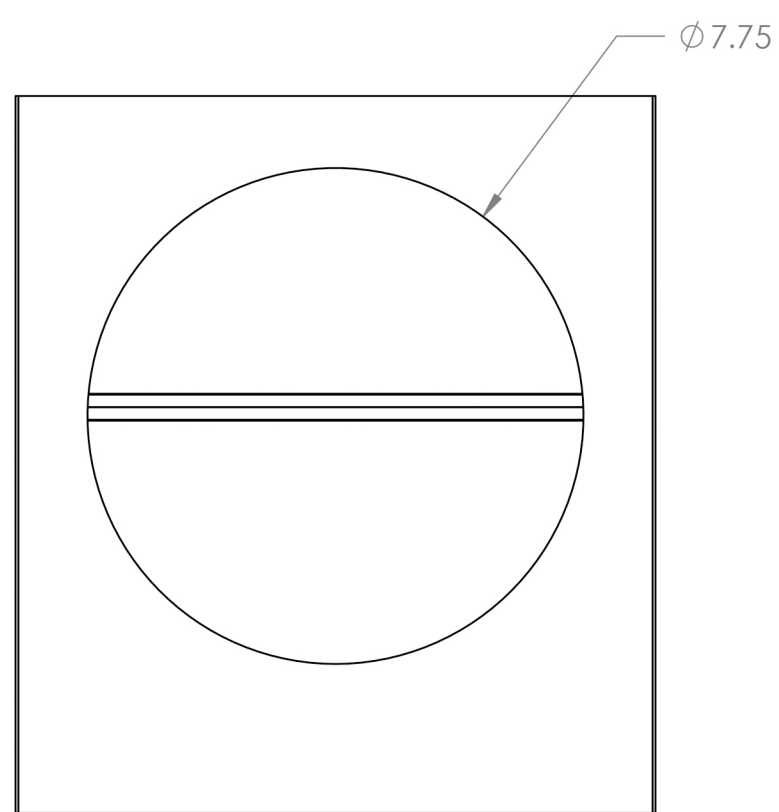

OPEN VENT WITH SCREEN AREA - 50 IN²

LAMBRO Lambro Industries, Inc.
 115 Albany Ave.
 Amityville, NY 11701
 (631) 842-8088
 www.lambro.net

PROPRIETARY AND CONFIDENTIAL
 THE INFORMATION CONTAINED IN THIS DRAWING IS THE SOLE PROPERTY OF LAMBRO. ANY REPRODUCTION IN PART OR AS A WHOLE WITHOUT THE WRITTEN PERMISSION OF LAMBRO IS PROHIBITED.

UNLESS OTHERWISE SPECIFIED:		NAME	DATE
DIMENSIONS ARE IN INCHES	DRAWN		
TOLERANCES:	CHECKED		
FRACTIONAL ± 1/16	ENG APPR.		
ANGULAR: MACH ± 1 BEND ± .01	MFG APPR.		
TWO PLACE DECIMAL ± 0.01	Q.A.		
THREE PLACE DECIMAL ± 0.005	COMMENTS:		
INTERPRET GEOMETRIC TOLERANCING PER:	Net Free Area (NFA)		
MATERIAL	34 sq. in.		
FINISH	Spring controlled damper		
NEXT ASSY	USED ON		
APPLICATION	DO NOT SCALE DRAWING		

TITLE: 8" Galvanized Wall Exhaust Hood Vent Flush Mount - Damper		
Cover & Base: 26 Gauge Damper: 28 Gauge		
SIZE	DWG. NO.	REV
	C 3480GNT	
SCALE: 1:3	WEIGHT:	SHEET 1 OF 1

4

3

2

1

D

D

C

C

B

B

A

A